

Series
VENTS VUT 160 V EC
VENTS VUT 350 VB EC
VENTS VUT 550 VB EC



Air handling unit in heat- and sound-insulated casing.
 Air capacity up to **700 m³/h**,
 heat recovery efficiency up to 98 %

■ **Description**

The air-handling units are the fully featured ventilation units with heat recovery for air filtration, fresh air supply and stale air extract. The heat contained in the extract air is recuperated in the high-efficient plate counter-flow heat exchanger to warm up supply air. The units are designed for energy efficient ventilation of cottages and flats and are compatible with round air ducts.

■ **Casing**

Made of high-quality polymer coated steel sandwich, internally filled with 20 mm mineral wool heat- and sound-insulating layer.

■ **Filter**

Supply and exhaust airflows are purified through panel filters with filtering class G4. A replaceable filter with filtering class F7 is optionally available.

■ **Fans**

High efficient electronically commutated motors

with external rotor and impeller with backward curved blades. Such motors are the most state-of-the-art energy saving solution. EC motors are featured with high performance and total speed controllable range. High efficiency reaching 90% is the premium advantage of the electronically commutated motors.

■ **Heat exchanger**

Counter-flow polystyrene heat exchangers with high heat recovery efficiency. The drain pan under the heat exchanger block ensures condensate removal. In case of freezing danger determined by the temperature sensor, the supply fan is turned off for the period required for the heat exchanger defrosting. The heat exchanger is easily removed for cleaning.

■ **Bypass**

The **VUT 350 & 550 VB EC** units are equipped with a 100 % bypass which can be opened if there is a need to cool down the ventilated area with cool intake air.

■ **Control and automation**

The unit includes integrated automation. The heat exchanger freezing protection operates as follows: In case of freezing danger determined by the temperature sensor the supply fan is turned off to let extract air warm up the heat exchanger. After freezing danger is no longer imminent, the unit reverts to the standard operation mode.

Delivery set includes a multifunctional control panel and a 10 m long signaling cable.

■ **Sensor control panel (A14)**

The **VUT V 160 EC A14**, **VUT VB 350 A14** and **VUT 550 VB EC A14** units are equipped with A14 sensor control panel with LED indication and following functions:



- Speed selection: Off, Low, Medium or High;
- Manual opening and closing of the bypass damper;
- Filter maintenance indication and resetting of the maintenance timer;
- Fault indication.



The **VUT V 160 EC A14**, **VUT VB 350 A14** and **VUT 550 VB EC A14** units can be connected to the PC by means of USB cable. Special software gives following possibilities:

- Software update of the unit;
- Adjusting of the Off, Low, Medium or High speed modes from 0 to 100 % for supply and exhaust fans separately;
- Adjustment of the humidity level and the speed activated by optional humidity sensor HV2;
- Adjustment of the speed activated by the optional external relay;
- Adjustment of the temperature of activation of freezing protection;
- Adjustment of filter maintenance timer;
- Monitoring of the maintenance timer, humidity level, external relay, and bypass;
- Error code indication.

■ **PU SENS 01 control panel (A11)**

The **VUT V 160 EC A11**, **VUT VB 350 A11** and **VUT 550 VB EC A11** units are equipped with touch-screen LCD control panel PU SENS 01 with following functions:



- Turning unit on/off;
- Low-medium-high speed selection and adjustment from 0 up to 100% for supply and exhaust fans separately;
- Manual or automatic opening/closing of the bypass for summer ventilation;
- Timer;
- Week scheduled;
- Actuating external air dampers;
- Indication, adjustment and maintaining set room or supply air temperature;
- Control according to the optional duct humidity sensor HV1 feedback or according to the humidity sensor built-in the control panel;
- Filter clogging control by motor hours;
- Ventilation system shutdown at signal from the fire alarm system;
- Cooler connection possibility.

Designation key:

Series	Rated air capacity [m ³ /h]	Duct connection	Bypass	Motor type	Control
VENTS VUT	160; 350; 550	V – vertical	– – no bypass; B – bypass	EC – synchronous electronically commutated motor	A11 – touch-screen LCD control panel PU SENS 01; A14 – sensor control panel with LED indication

Accessories



page 368 page 368 page 430 page 435 page 443 page 480 page 480 Duct humidity sensor HV1 Duct humidity sensor HV2

■ Mounting

The units are designed for the wall mounting. Ac-

cess for the unit servicing and filter maintenance on the front panel side. During mounting stage, service

panel can be installed on the left or right side of the unit along the supply airflow path.

Technical data:

	VUT 160 V EC	VUT 350 VB EC	VUT 550 VB EC
Voltage [V / Hz]	1~ 220-240 / 50-60		
Max. fan power [W]	51	166	333
Max. unit current [A]	0.4	1.3	2.3
Max. air capacity [m ³ /h]	180	415	700
RPM	3770	3200	3230
Sound pressure level at 3 m [dBA]	44	51	55
Transported air temperature [°C]	-25 up to +60		
Casing material	polymer coated steel		
Insulation	20 mm mineral wool		
Extract filter	G4		
Supply filter	G4 (F7*)		
Connected air duct diameter [mm]	Ø 125	Ø 160	Ø 200
Weight [kg]	34	56	65
Heat recovery efficiency, %	88 up to 98	85 up to 98	81 up to 97
Heat exchanger type	counter-flow		
Heat exchanger material	polystyrene		

*option

Overall dimensions:

Type	Dimensions [mm]						
	Ø D	B1	H	H1	L	L1	L2
VUT 160 V EC	125	330	650	550	600	388	143
VUT 350 VB EC	160	544	732	629	687	426	220
VUT 550 VB EC	200	674	732	629	780	493	244

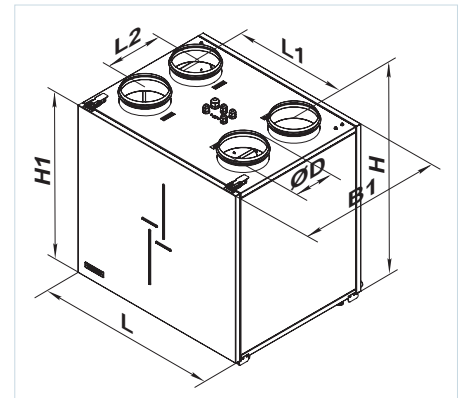

VENTS VUT
 160 V EC /
 350 VB EC /
 550 VB EC
 HEAT RECOVERY AIR
 HANDLING UNITS

Air handling unit accessories:

Type	G4 replaceable panel filter	F7 replaceable panel filter	Duct humidity sensor	Siphon kit
VUT 160 V EC A14	SF VUT 160 V EC G4	SF VUT 160 V EC F7		
VUT 350 VB EC A14	SF VUT 350 VB EC G4	SF VUT 350 VB EC F7	HV2	
VUT 550 VB EC A14	SF VUT 550 VB EC G4	SF VUT 550 VB EC F7		
VUT 160 V EC A11	SF VUT 160 V EC G4	SF VUT 160 V EC F7		SH-32
VUT 350 VB EC A11	SF VUT 350 VB EC G4	SF VUT 350 VB EC F7	HV1	
VUT 550 VB EC A11	SF VUT 550 VB EC G4	SF VUT 550 VB EC F7		

VENTS VUT 160 V EC

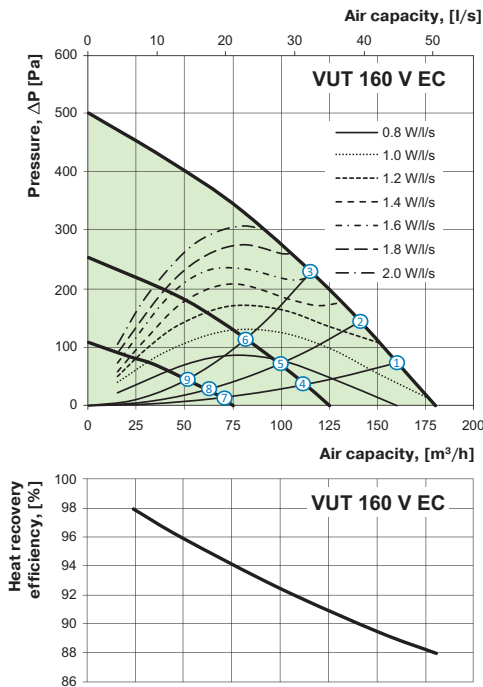

Sound pressure level, A-weighted	Hz	Octave-frequency band [Hz]								LpA, 3m dBA	LpA, 1m dBA	
		Gen	63	125	250	500	1000	2000	4000			8000
L _{WA} to supply inlet	dBA	52	28	46	49	41	35	33	36	29	31	41
L _{WA} to supply outlet	dBA	60	32	52	58	47	37	36	41	35	39	49
L _{WA} to exhaust inlet	dBA	51	27	45	49	41	36	32	35	29	31	41
L _{WA} to exhaust outlet	dBA	60	31	50	59	48	36	36	41	32	39	49
L _{WA} to environmet	dBA	45	25	41	42	34	31	28	27	22	24	34

*Data provided for point 1 of the air flow diagram

VENTS VUT 350 VB EC

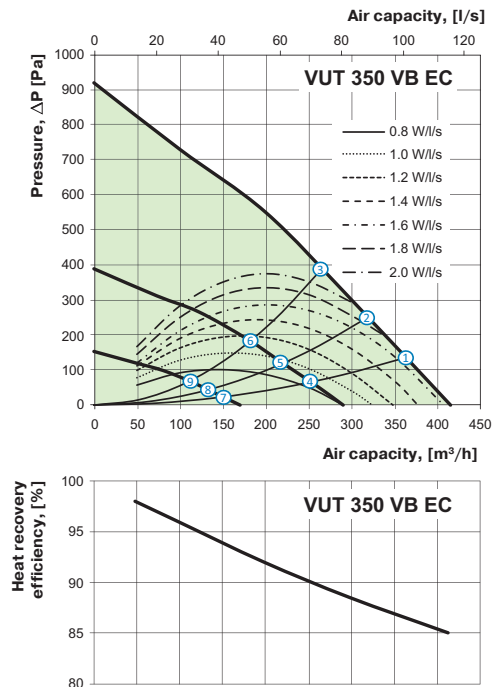

Sound pressure level, A-weighted	Hz	Octave-frequency band [Hz]								LpA, 3m dBA	LpA, 1m dBA	
		Gen	63	125	250	500	1000	2000	4000			8000
L _{WA} to supply inlet	dBA	56	50	46	53	45	39	34	36	32	35	45
L _{WA} to supply outlet	dBA	64	56	52	63	52	39	38	43	35	44	54
L _{WA} to exhaust inlet	dBA	56	52	46	53	45	38	34	36	31	36	46
L _{WA} to exhaust outlet	dBA	64	58	53	62	51	40	38	42	33	44	54
L _{WA} to environmet	dBA	49	45	40	44	38	33	29	27	22	28	38

*Data provided for point 1 of the air flow diagram

VENTS VUT 550 VB EC

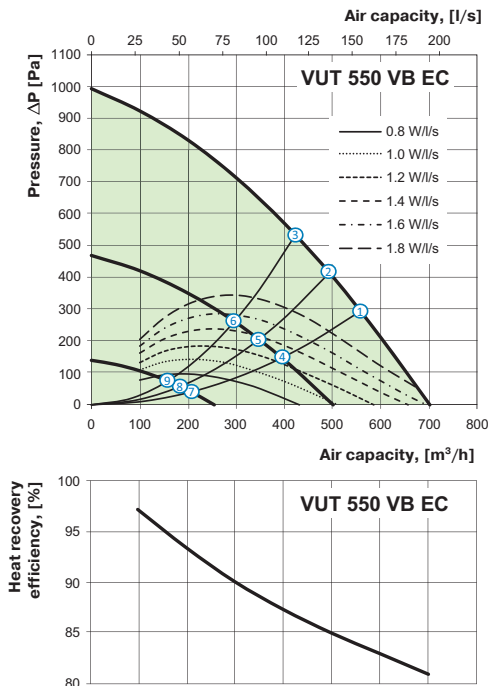

Sound pressure level, A-weighted	Hz	Octave-frequency band [Hz]								LpA, 3m dBA	LpA, 1m dBA	
		Gen	63	125	250	500	1000	2000	4000			8000
L _{WA} to supply inlet	dBA	57	50	45	54	46	42	42	42	32	36	46
L _{WA} to supply outlet	dBA	62	59	47	58	51	43	41	43	39	42	52
L _{WA} to exhaust inlet	dBA	56	48	43	54	45	35	34	36	32	35	45
L _{WA} to exhaust outlet	dBA	62	58	47	59	51	43	40	43	37	41	51
L _{WA} to environmet	dBA	49	44	39	45	38	33	30	28	23	28	38

*Data provided for point 1 of the air flow diagram

Point	Power [W]		
	VUT 160 V EC	VUT 350 VB EC	VUT 550 VB EC
1	50	165	332
2	51	165	331
3	50	165	332
4	22	63	133
5	22	62	129
6	21	60	126
7	9	21	32
8	9	20	31
9	9	20	30

Point	Total sound pressure level at 3 m (1 m), dB(A)		
	VUT 160 V EC	VUT 350 VB EC	VUT 550 VB EC
1	24 (34)	28 (38)	28 (38)
2	23 (33)	27 (37)	28 (38)
3	23 (33)	27 (37)	27 (37)
4	20 (30)	23 (33)	23 (33)
5	20 (30)	22 (32)	23 (33)
6	20 (30)	22 (32)	22 (32)
7	13 (23)	15 (25)	15 (25)
8	13 (23)	14 (24)	15 (25)
9	13 (23)	14 (24)	14 (24)

Unit design:

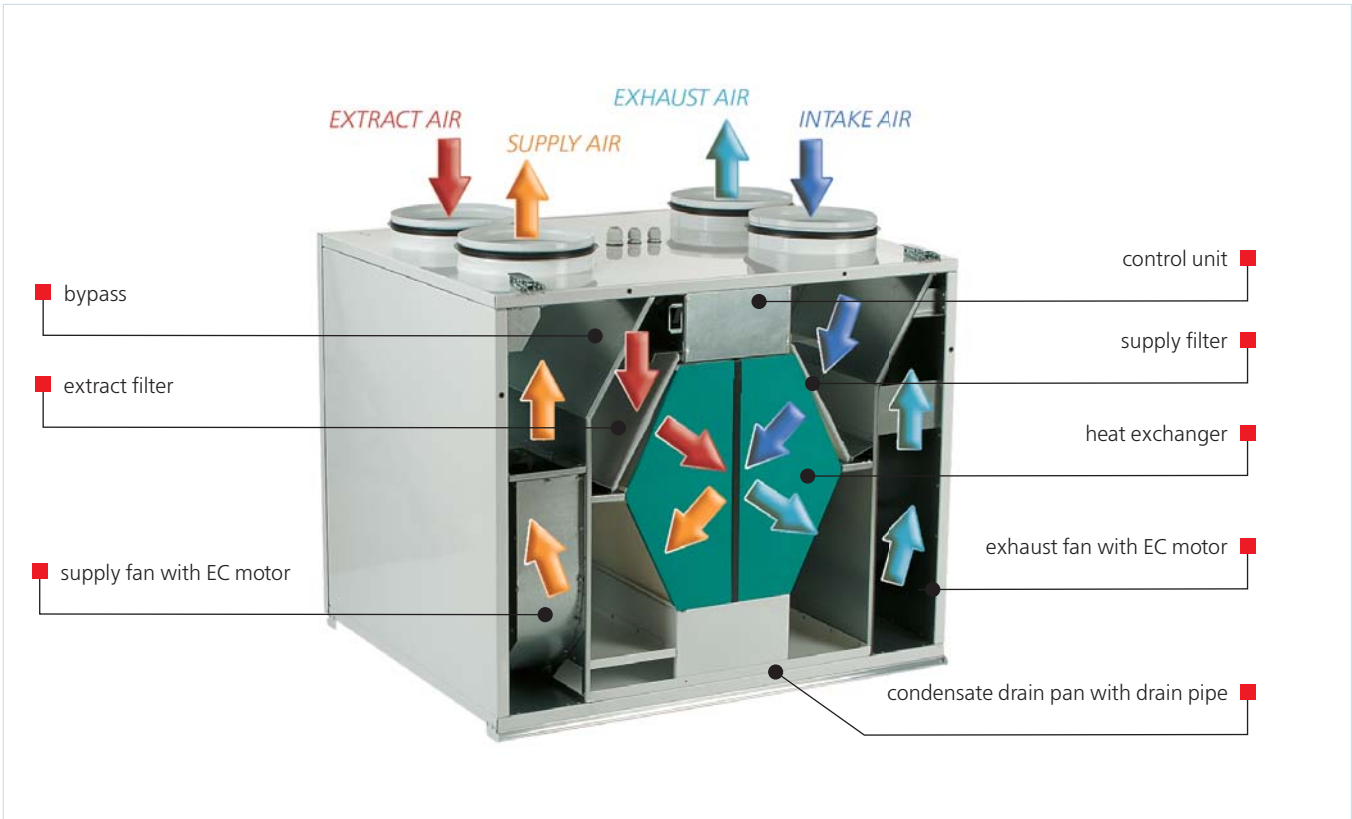

Application example:



VENTS VUT
160 V EC /
350 VB EC /
550 VB EC
HEAT RECOVERY AIR
HANDLING UNITS